

# RUSSELL PUMP & ENGINEERING

## Boiler Feed Type BFF Simplex and Duplex



### Introduction:

Boiler Feed units are compact assemblies for returning condensate make-up water to low pressure steam boilers, in a gravity return system, from low pressure steam process equipment or from a combination of both. Our units are designed for installation where it is necessary to maintain the boiler water line within narrow limits and to automatically supply make-up from a separate service. Standard equipment includes stainless steel tank, saddles, gauge glass & cocks, make up valve and switch. The design of the pumps are so that the abrasive action of the scale and rust usually found in heating return systems will not seriously affect the efficiency and long life of the pump. These boiler feed units are easy to install, and ready for operation after piping and wiring connections are made. Boiler water line control is accomplished by governing the pump operation with a boiler water level controller installed at the boiler water line. When the boiler requires water the float operated switch in the controller starts the pump motor(s). Water level is maintained in the pump receiver by condensate from the system flowing by gravity into the pump tank and by the float controlled make up valve connected to a city water supply or other source.

**RUSSELL PUMP AND ENGINEERING**  
**102 WEST CHICAGO ST., ALBION, IA 50005**  
**641-488-2319**

# Dimensions

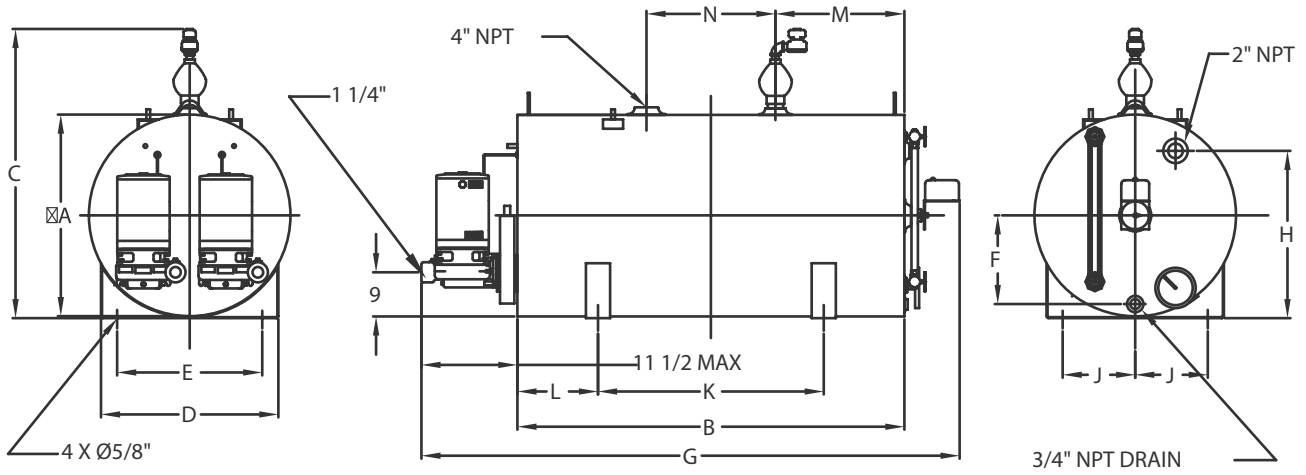

GAL	A	B	HEAD GAUGE	SHELL GAUGE	C *	D	E	F	G **	H	J	K	L	M	N
100	25	48	12	12	34	22	18	23 1/8	66 1/2	20 3/4	4	28	10	16	16
150	31	48	10	12	40	25	19	26 1/8	66 1/2	27	4	28	10	16	16
200	32	60	10	10	41	26	20	27 1/8	90 1/2	28 1/4	4	36	12	20	20
250	32	72	10	10	41	26	20	27 1/8	90 1/2	28 1/4	4	44	14	24	24
300	36	72	10	10	45	27 3/4	21 3/4	29 1/2	90 1/2	32 1/4	10	44	14	24	24

NOTE:

\* ADD 5 1/2" FOR OPTIONAL AIR GAP

\*\* ADD 2 1/2" FOR OPTIONAL BUTTERFLY VALVE

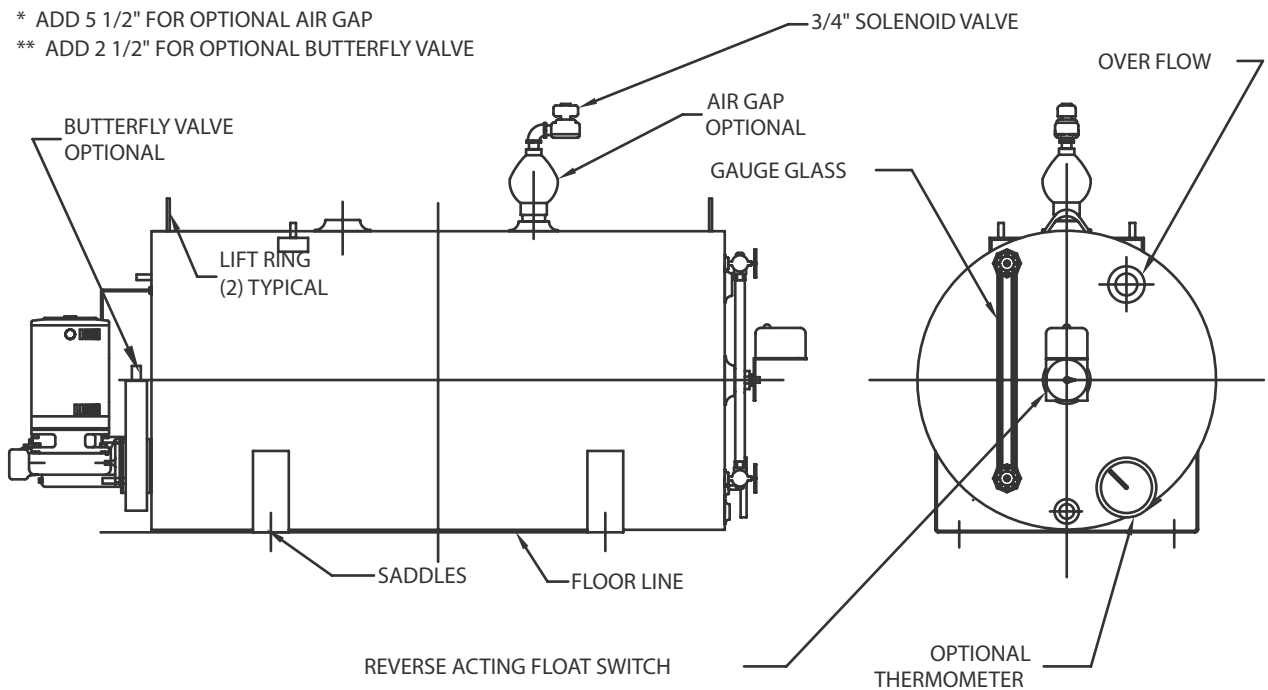

## Design Features—Construction

The tank is made of 10 gauge stainless steel, welded construction, with stainless steel saddles, the heads are made of 3/16" stainless steel. The tank is available in 5 standard sizes, other sizes contact factory for availability.

The pump is constructed of ASTM A48 class 30 cast iron. The mechanical seal is a Type 21 bu-na-n seal and is rated to 225°F and pressures to 175PSI. Carbon seal face mates with the ceramic seat providing years of trouble free service. The hydraulic design of the impeller maximizes pressure and gpm while minimizing horsepower. The enclosed impeller is made of cast bronze. The precise machining of the adapter allows for easy assembly of the pump. Construction consists of ASTM A48 class 30 cast iron.

The NEMA 56J motor utilizes a stainless steel shaft. The motors heavy duty ball bearings withstand axial and radial thrust loads with no problem. Standard enclosure type is dripproof, alternates are available, consult factory.

The capacity tables are arranged for a variety of loads, discharge pressures and tank sizes. If the boiler is at a higher level or some distance care should be taken in the selection of a pump with sufficient discharge pressure to more than equal A) the maximum boiler pressure, plus B) the difference in elevation reduced to pounds (2.31 feet equals 1 pound) plus C) the friction head sufficiently to permit the selection of a pump having a lower discharge pressure.

MODEL	SIZES	PSI	COND. RATE GPM	PUMP GPM CAPACITY	HP	RPM	TANK SIZE	GALLON	WEIGHT SIMPLEX	WEIGHT DUPLEX
620	6,000 EDR	20	3	9	1/3	3450	25 X 48	100	330	370
	43 BHP				31 X 48		150	383	425	
630	120M BTU	30			1/2		32 X 60	200	513	558
					32 X 72		250	590	641	
							36 X 72	300	XXX	XXX
1020	10,000 EDR	20	5	15	1/3	3450	25 X 48	100	330	370
	71 BHP				31 X 48		150	383	425	
1030	480M BTU	30			1/2		32 X 60	200	513	558
					32 X 72		250	590	641	
							36 X 72	300	XXX	XXX
2020	20,000 EDR	20	10	30	1/2	3450	25 X 48	100	335	375
	153 BHP				31 X 48		150	386	431	
2030	480M BTU	30			3/4		32 X 60	200	519	564
					32 X 72		250	593	647	
							36 X 72	300	XXX	XXX
3020	30,000 EDR	20	15	35	3/4	3450	25 X 48	100	340	390
	214 BHP				31 X 48		150	390	437	
3030	720M BTU	30			1 1/2		32 X 60	200	522	570
					32 X 72		250	596	653	
							36 X 72	300	XXX	XXX

# Specifications

## Simplex Boiler Feed Pump

The contractor shall furnish and install as specified in the plans and in accordance with the manufacturer's instructions RUSSELL PUMP AND ENGINEERING type BFF Simplex Boiler Feed Pump, catalog number which has a rating of \_\_\_\_\_ GPM at \_\_\_\_\_ PSI.

The pump shall consist of a welded 304 stainless steel tank (\_\_\_\_\_ gallon capacity, \_\_\_\_\_ gauge thick heads and \_\_\_\_\_ gauge shell, \_\_\_\_\_x\_\_\_\_\_), two welded support saddles, a reverse acting float switch wired to an electric solenoid make-up valve. and a vertically mounted close coupled pump.

The centrifugal pump shall be bronze fitted, have an enclosed impeller, a mechanical seal rated at 225 degrees Fahrenheit and 75 psig, a case of volute design and shall be driven by a \_\_\_\_\_hp motor operating at \_\_\_\_\_RPM. The pump shall be powered by \_\_\_\_\_Volts \_\_\_\_\_Phase \_\_\_\_\_Hertz. In addition the unit can be furnished with starting equipment to include a NEMA 1 magnetic starter and selector switch.

Job Name \_\_\_\_\_ Location \_\_\_\_\_

Door Size \_\_\_\_\_x\_\_\_\_\_

## Duplex Boiler Feed Pump

The contractor shall furnish and install as specified in the plans and in accordance with the manufacturer's instructions RUSSELL PUMP AND ENGINEERING type BFFD Duplex Boiler Feed Pump, catalog number which has a rating of \_\_\_\_\_ GPM at \_\_\_\_\_ PSI.

The pump shall consist of a welded 304 stainless steel tank (\_\_\_\_\_gallon capacity, \_\_\_\_\_ gauge thick heads and \_\_\_\_\_gauge shell, \_\_\_\_\_x\_\_\_\_\_), two welded support saddles, a reverse acting float switch wired to an electric solenoid make-up valve. and a vertically mounted close coupled pump.

The centrifugal pumps shall be bronze fitted, have an enclosed impeller, a mechanical seal rated at 225 degrees Fahrenheit and 75 psig, a case of volute design and shall be driven by a \_\_\_\_\_ hp motor operating at \_\_\_\_\_RPM. The pumps shall be powered by \_\_\_\_\_Volts \_\_\_\_\_Phase \_\_\_\_\_Hertz. In addition the unit(s) can be furnished with starting equipment to include a NEMA 1 magnetic starter and selector switch.

Job Name \_\_\_\_\_ Location \_\_\_\_\_

Door Size \_\_\_\_\_x\_\_\_\_\_

RUSSELL PUMP AND ENGINEERING  
102 WEST CHICAGO ST., ALBION, IA 50005  
641-488-2319